

TRADE-OFFS AMONG AI TECHNIQUES

Christian Kaestner

Required reading: Hulten, Geoff. "Building Intelligent Systems: A Guide to Machine Learning Engineering." (2018),
Chapters 17 and 18

LEARNING GOALS

- Organize and prioritize the relevant qualities of concern for a given project
- Explain the key ideas behind decision trees and random forests and analyze consequences for various qualities
- Explain the key ideas of deep learning and the reason for high resource needs during learning and inference and the ability for incremental learning
- Plan and execute an evaluation of the qualities of alternative AI components for a given purpose

**RECALL: ML IS A
COMPONENT IN A SYSTEM
IN AN ENVIRONMENT**

00:00  Offset 00:00 01:31:27

Play



Back 5s

1x

Speed



Volume

NOTES

Write your notes here

Speaker 5 ▶ 07:44

Yeah. So there's a slight story behind that. So back when I was in, **uh**, Undergrad, I wrote a program for myself to measure a, **the** amount of time I did data entry **from** my father's business and I was on windows at the time and there wasn't a function called time dot **[inaudible]** time, **uh**, which I **needed** to parse dates to get back to time, **top** of representation, **uh**, I figured out a way to do it and I gave it to what's called the python cookbook because it just seemed like something other people could use. So **it was** just trying to be helpful. **Uh**, subsequently I had to figure out how to make it work **because** I didn't really have to. Basically, it bothered me that you had to input all the **locale** information and I figured out how to do it over **the subsequent months**. And actually as a graduation gift from my Undergrad, the week following, I solved it and wrote it all out.

Speaker 5 ▶ 08:38

And I asked, **uh**, Alex Martelli, the editor of the Python Cookbook, which had published my original recipe, **a**, how do I get this into python? I think **it** might help

How did we do on your transcript?



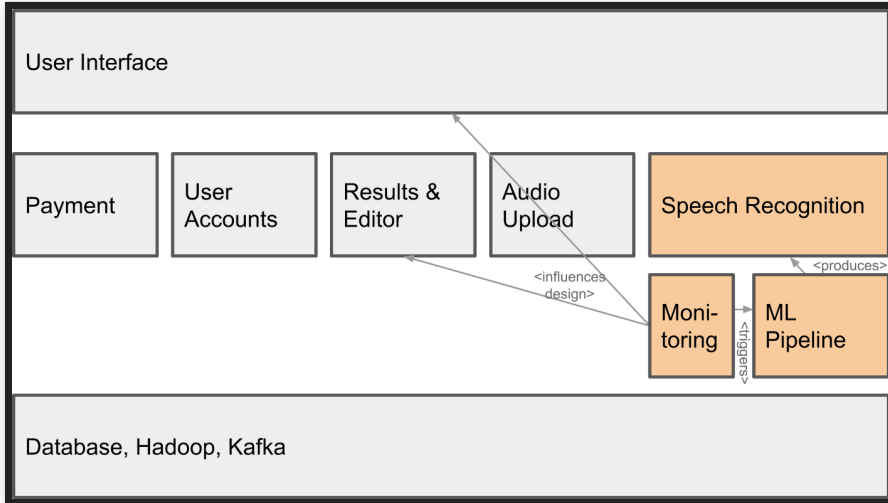

- Transcription model, pipeline to train the model, monitoring infrastructure
- NonML components for data storage, user interface, payment processing, ...
- User requirements and assumptions
- System quality vs model quality
- System requirements vs model requirements

IDENTIFY RELEVANT QUALITIES OF AI COMPONENTS IN AI- ENABLED SYSTEMS

(Requirements Engineering)

QUALITY



ACCURACY IS NOT EVERYTHING

Beyond prediction accuracy, what qualities may be relevant for an AI component?



Speaker notes

Collect qualities on whiteboard

DIFFERENT ASPECTS OF QUALITY

- **Transcendent** – Experiential. Quality can be recognized but not defined or measured
- **Product-based** – Level of attributes (More of this, less of that)
- **User-based** – Fitness for purpose, quality in use
- **Value-based** – Level of attributes/fitness for purpose at given cost
- **Manufacturing** – Conformance to specification, process excellence

- **Quality attributes:** How well the product (system) delivers its functionality
- **Project attributes:** Time-to-market, development & HR cost...
- **Design attributes:** Type of method used, development cost, operating cost, ...

Reference: Garvin, David A., [What Does Product Quality Really Mean](#). Sloan management review 25 (1984).

QUALITIES OF INTEREST?

Scenario: Component transcribing audio files for transcription startup

the-changelog-318 ← Dashboard | Quality: High ⓘ Last saved a few seconds ago ... Share

00:00 Offset 00:00 01:31:27

▶ Play ↺ Back 5s 1x Speed 🔊 Volume

NOTES
Write your notes here

Speaker 5 ▶ 07:44

Yeah. So there's a slight story behind that. So back when I was in, uh, Undergrad, I wrote a program for myself to measure a, the amount of time I did data entry from my father's business and I was on windows at the time and there wasn't a function called time dot [inaudible] time, uh, which I needed to parse dates to get back to time, top of representation, uh, I figured out a way to do it and I gave it to what's called the python cookbook because it just seemed like something other people could use. So it was just trying to be helpful. Uh, subsequently I had to figure out how to make it work because I didn't really have to. Basically, it bothered me that you had to input all the locale information and I figured out how to do it over the subsequent months. And actually as a graduation gift from my Undergrad, the week following, I solved it and wrote it all out.

Speaker 5 ▶ 08:38

And I asked, uh, Alex Martelli, the editor of the Python Cookbook, which had published my original recipe, a, how do I get this into python? I think it might help

How did we do on your transcript? ☆☆☆☆☆

Speaker notes

Which of the previously discussed qualities are relevant? Which additional qualities may be relevant here? Cost per transaction?

QUALITIES OF INTEREST?

Scenario: Component detecting line markings in camera picture in car

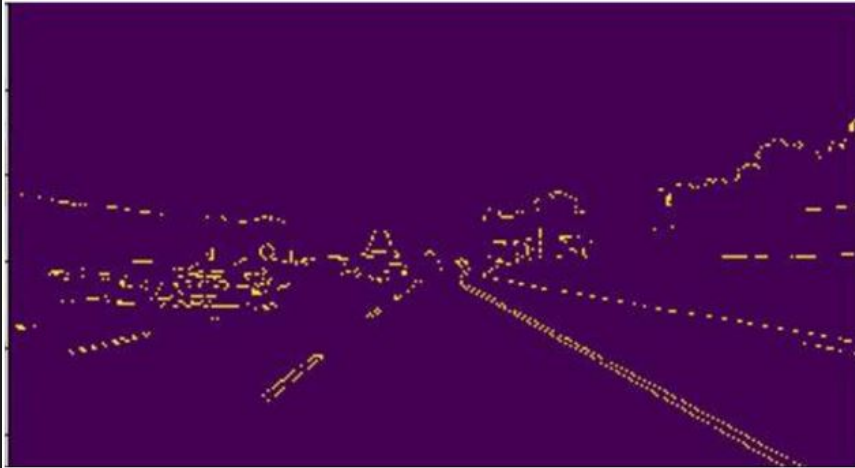

Canny edge detection output

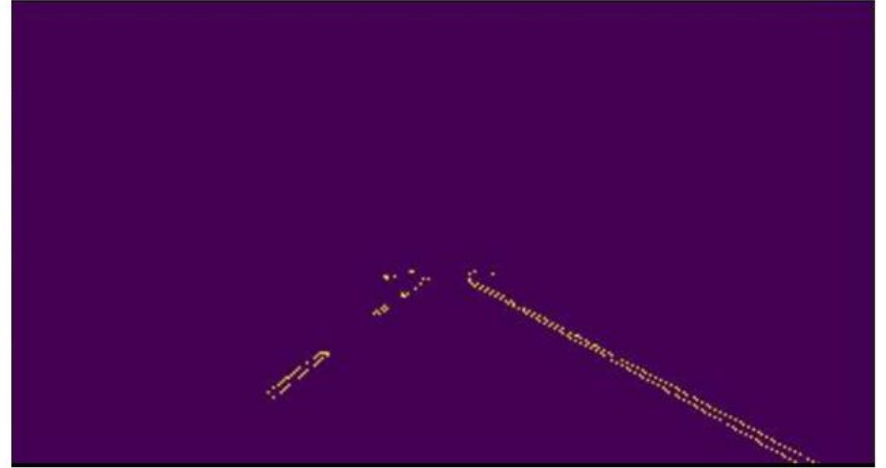

Hough transform output

Speaker notes

Which of the previously discussed qualities are relevant? Which additional qualities may be relevant here? Realtime use

QUALITIES OF INTEREST?

Scenario: Component detecting credit card fraud as a service provider to many banks



Note: Very high volume of transactions, low cost per transaction, frequent updates

EXAMPLES OF QUALITIES TO CONSIDER

- Accuracy
- Correctness guarantees? Probabilistic guarantees (--> symbolic AI)
- How many features? Interactions among features?
- How much data needed? Data quality important?
- Incremental training possible?
- Training time, memory need, model size -- depending on training data volume and feature size
- Inference time, energy efficiency, resources needed, scalability
- Interpretability/explainability
- Robustness, reproducibility, stability
- Security, privacy
- Fairness

MEASURING QUALITIES

- Define a metric -- define units of interest
 - e.g., requests per second, max memory per inference, average training time in seconds for 1 million datasets
- Operationalize metric -- define measurement protocol
 - e.g., conduct experiment: train model with fixed dataset, report median training time across 5 runs, file size, average accuracy with leave-one-out crossvalidation after hyperparameter tuning
 - e.g., ask 10 humans to independently label evaluation data, report reduction in error from machine-learned model over human predictions
 - describe all relevant factors: inputs/experimental units used, configuration decisions and tuning, hardware used, protocol for manual steps

On terminology: *metric/measure* refer a method or standard format for measuring something; *operationalization* is identifying and implementing a method to measure some factor

ON TERMINOLOGY

- Data scientists seem to speak of *model properties* when referring to accuracy, inference time, fairness, etc
 - ... but they also use this term for whether a *learning technique* can learn non-linear relationships or whether the learning algorithm is monotonic
- Software engineering wording would usually be *quality attributes, non-functional requirements, ...*

DECISION TREES, RANDOM FORESTS, AND DEEP NEURAL NETWORKS

DECISION TREES

Outlook	Temperature	Humidity	Windy	Play
overcast	hot	high	false	yes
overcast	hot	high	false	no
overcast	hot	high	false	yes
overcast	cool	normal	true	yes
overcast	mild	high	true	yes
overcast	hot	normal	false	yes
rainy	mild	high	false	yes
rainy	cool	normal	false	yes
rainy	cool	normal	true	no
rainy	mild	normal	false	yes
rainy	mild	high	true	no
sunny	hot	high	false	no
sunny	hot	high	true	no
sunny	mild	high	false	no
sunny	cool	normal	false	yes
sunny	mild	normal	true	yes

$f(\text{Outlook, Temperature, Humidity, Windy}) =$

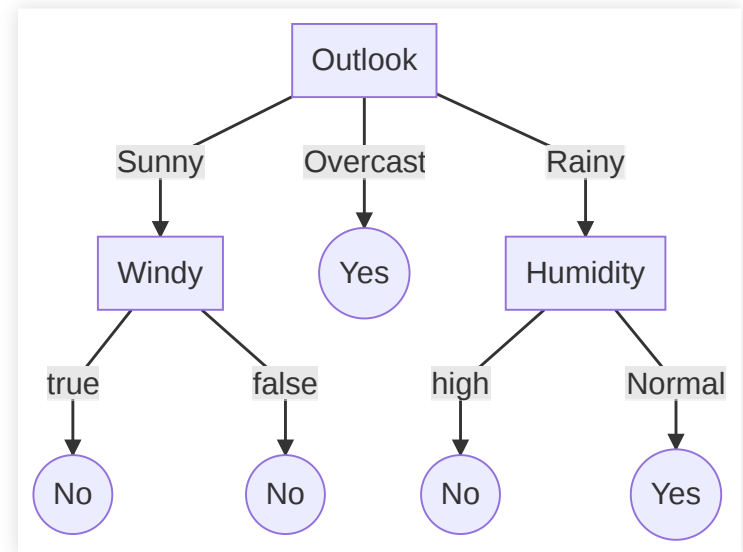

BUILDING DECISION TREES

Outlook	Temperature	Humidity	Windy	Play
overcast	hot	high	false	yes
overcast	hot	high	false	no
overcast	hot	high	false	yes
overcast	cool	normal	true	yes
overcast	mild	high	true	yes
overcast	hot	normal	false	yes
rainy	mild	high	false	yes
rainy	cool	normal	false	yes
rainy	cool	normal	true	no
rainy	mild	normal	false	yes
rainy	mild	high	true	no
sunny	hot	high	false	no
sunny	hot	high	true	no
sunny	mild	high	false	no
sunny	cool	normal	false	yes
sunny	mild	normal	true	yes

- Identify all possible decisions
- Select the decision that best splits the dataset into distinct outcomes (typically via entropy or similar measure)
- Repeatedly further split subsets, until stopping criteria reached

DECISION TREES

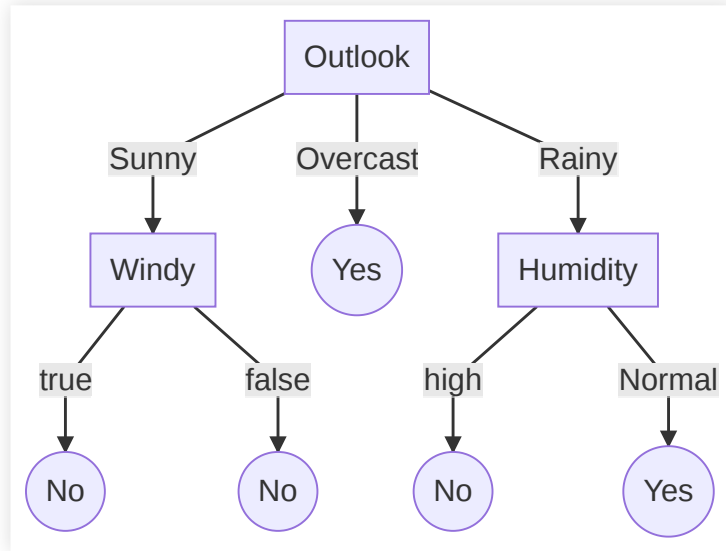

Qualities of vanilla decision trees?



- Identify all possible decisions
- Select the decision that best splits the dataset into distinct outcomes (typically via entropy or similar measure)
- Repeatedly further split subsets, until stopping criteria reached

Speaker notes

Obvious ones: fairly small model size, low inference cost, no obvious incremental training; easy to interpret locally and even globally if shallow; easy to understand decision boundaries

RANDOM FORESTS

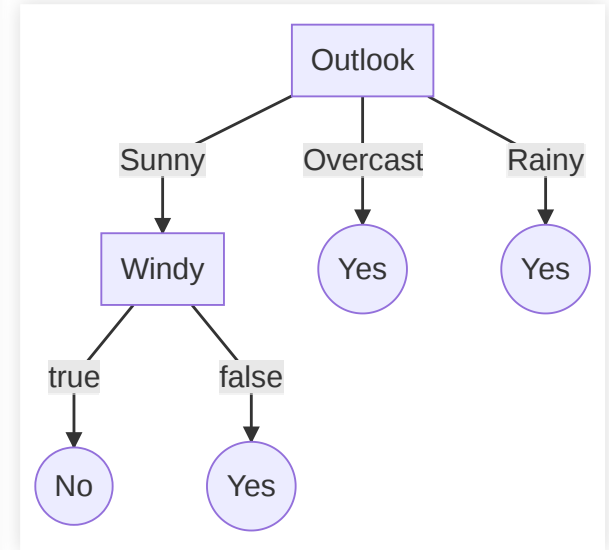
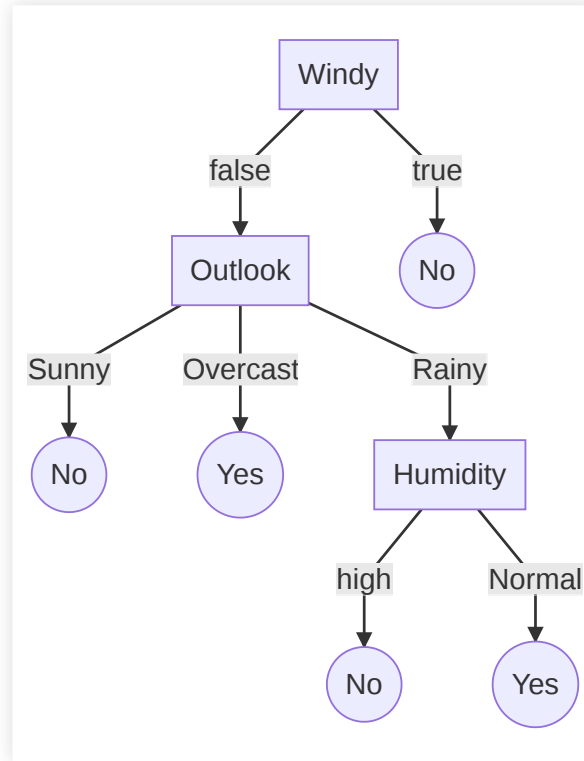
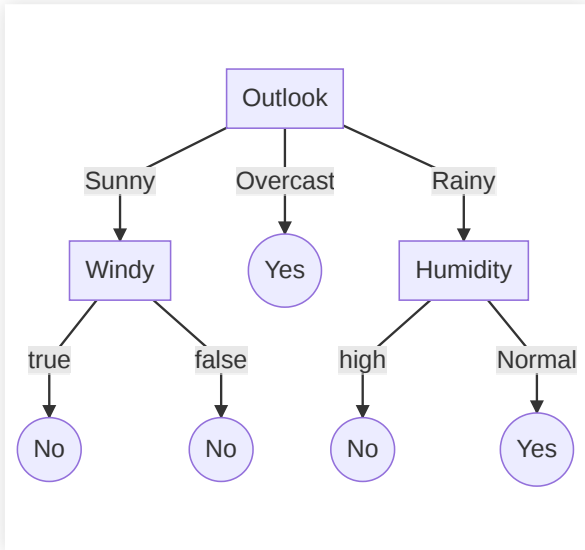

Train multiple trees on subsets of data or subsets of decisions. Return average prediction of multiple trees.

Qualities?

Speaker notes

Increased training time and model size, less prone to overfitting, more difficult to interpret

NEURAL NETWORKS

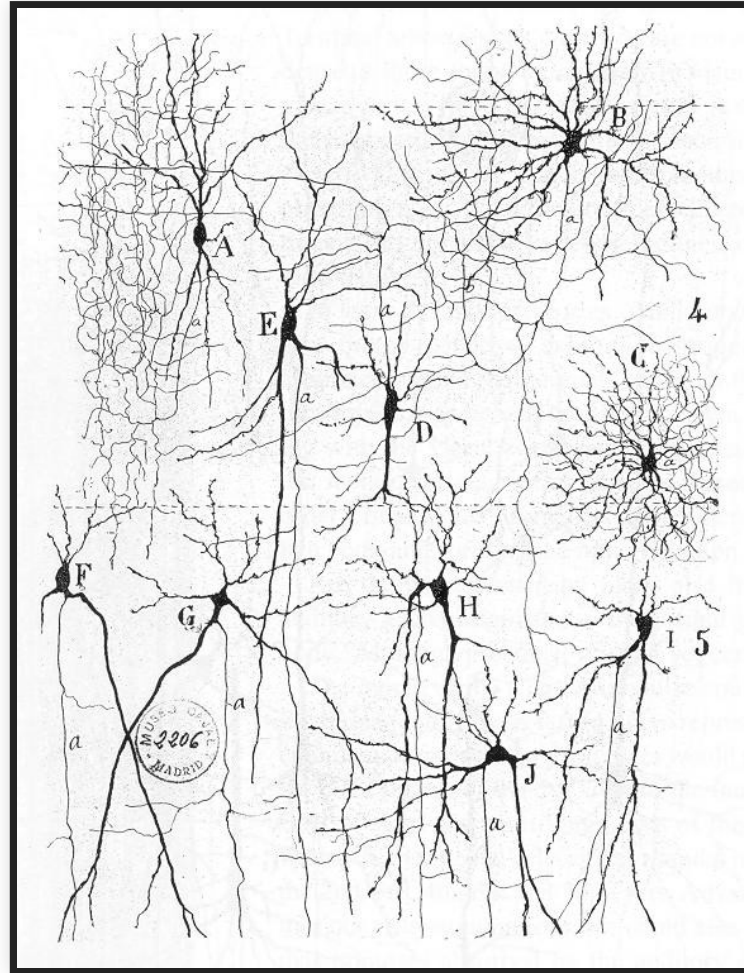

Speaker notes

Artificial neural networks are inspired by how biological neural networks work ("groups of chemically connected or functionally associated neurons" with synapses forming connections)

From "Texture of the Nervous System of Man and the Vertebrates" by Santiago Ramón y Cajal, via https://en.wikipedia.org/wiki/Neural_circuit#/media/File:Cajal_actx_inter.jpg

ARTIFICIAL NEURAL NETWORKS

Simulating biological neural networks of neurons (nodes) and synapses (connections), popularized in 60s and 70s

Basic building blocks: Artificial neurons, with n inputs and one output; output is activated if at least m inputs are active

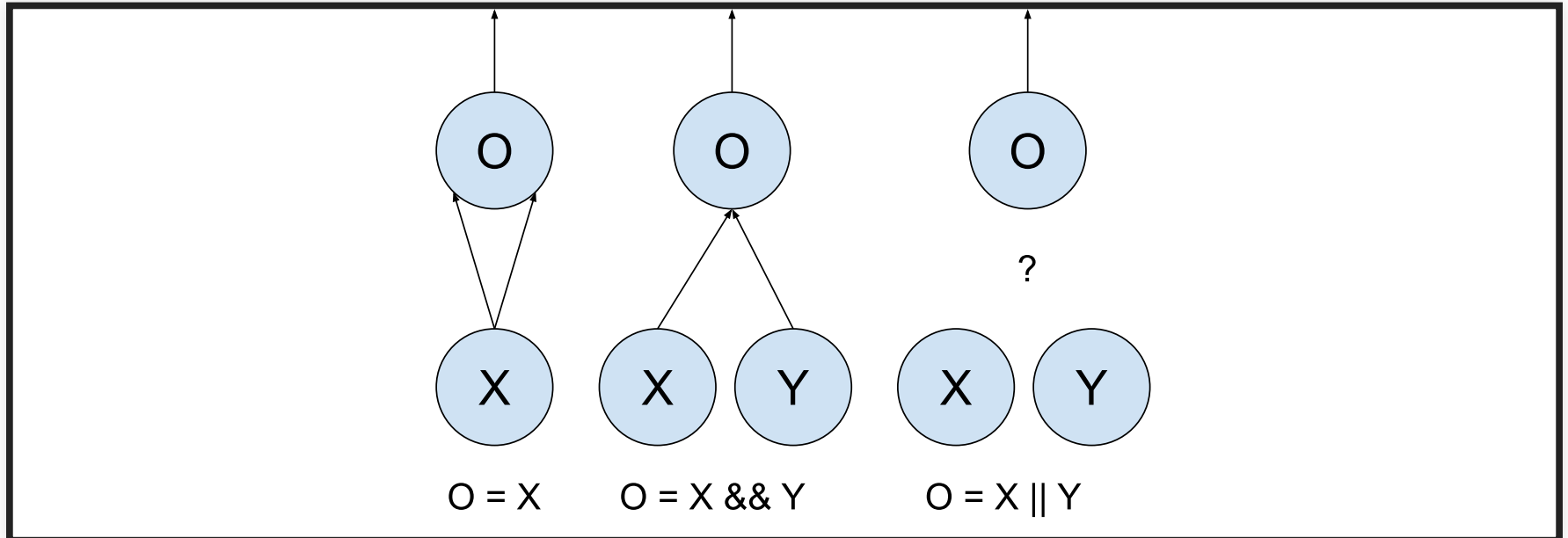

(assuming at least two activated inputs needed to activate output)

THRESHOLD LOGIC UNIT / PERCEPTRON

computing weighted sum of inputs + step function

$$z = w_1x_1 + w_2x_2 + \dots + w_nx_n = \mathbf{x}^T\mathbf{w}$$

e.g., step: $\phi(z) = \text{if } (z < 0) \text{ } 0 \text{ else } 1$

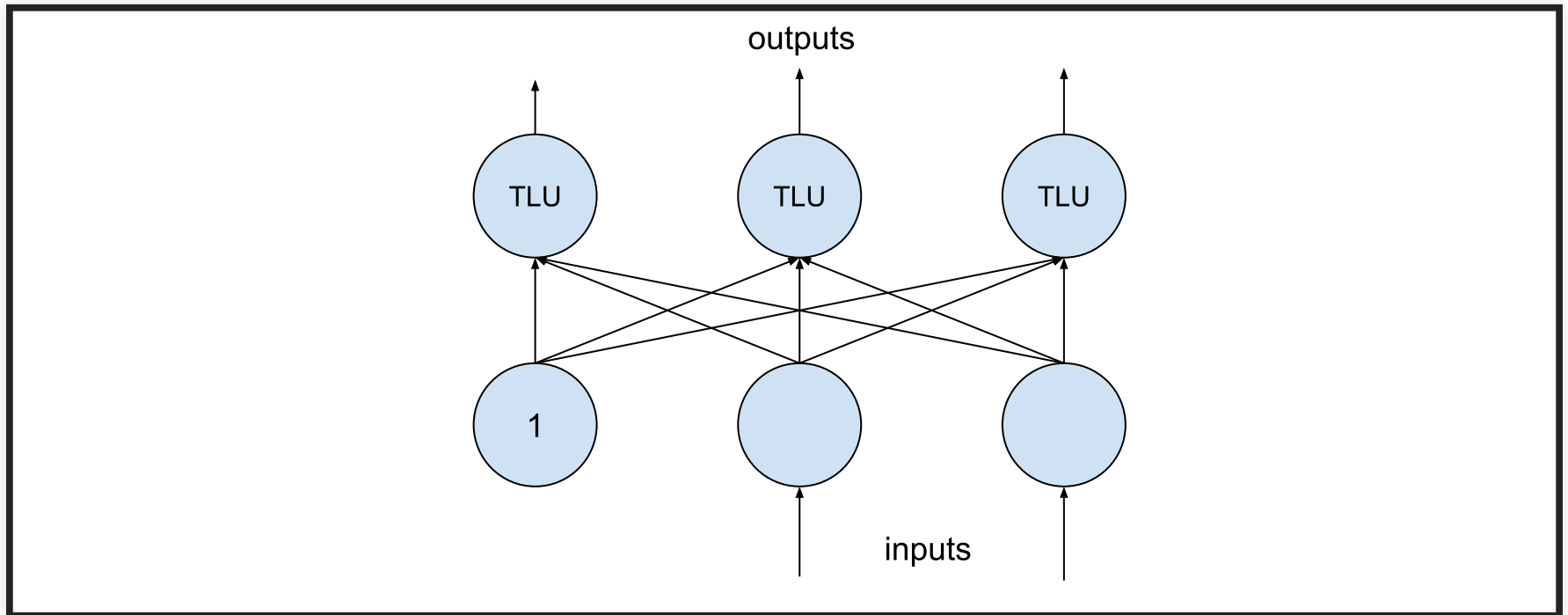

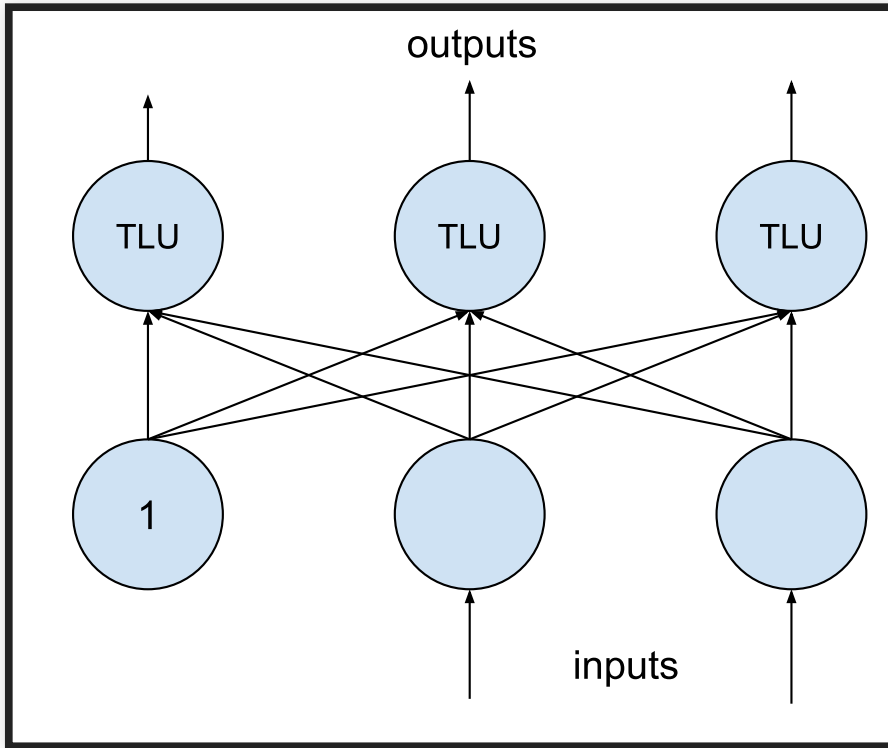

$$o_1 = \phi(b_1 + w_{1,1}x_1 + w_{1,2}x_2)$$

$$o_2 = \phi(b_2 + w_{2,1}x_1 + w_{2,2}x_2)$$

$$o_3 = \phi(b_3 + w_{3,1}x_1 + w_{3,2}x_2)$$

$$f_{\mathbf{W}, \mathbf{b}}(\mathbf{X}) = \phi(\mathbf{W} \cdot \mathbf{X} + \mathbf{b})$$

(\mathbf{W} and \mathbf{b} are parameters of the model)

MULTIPLE LAYERS

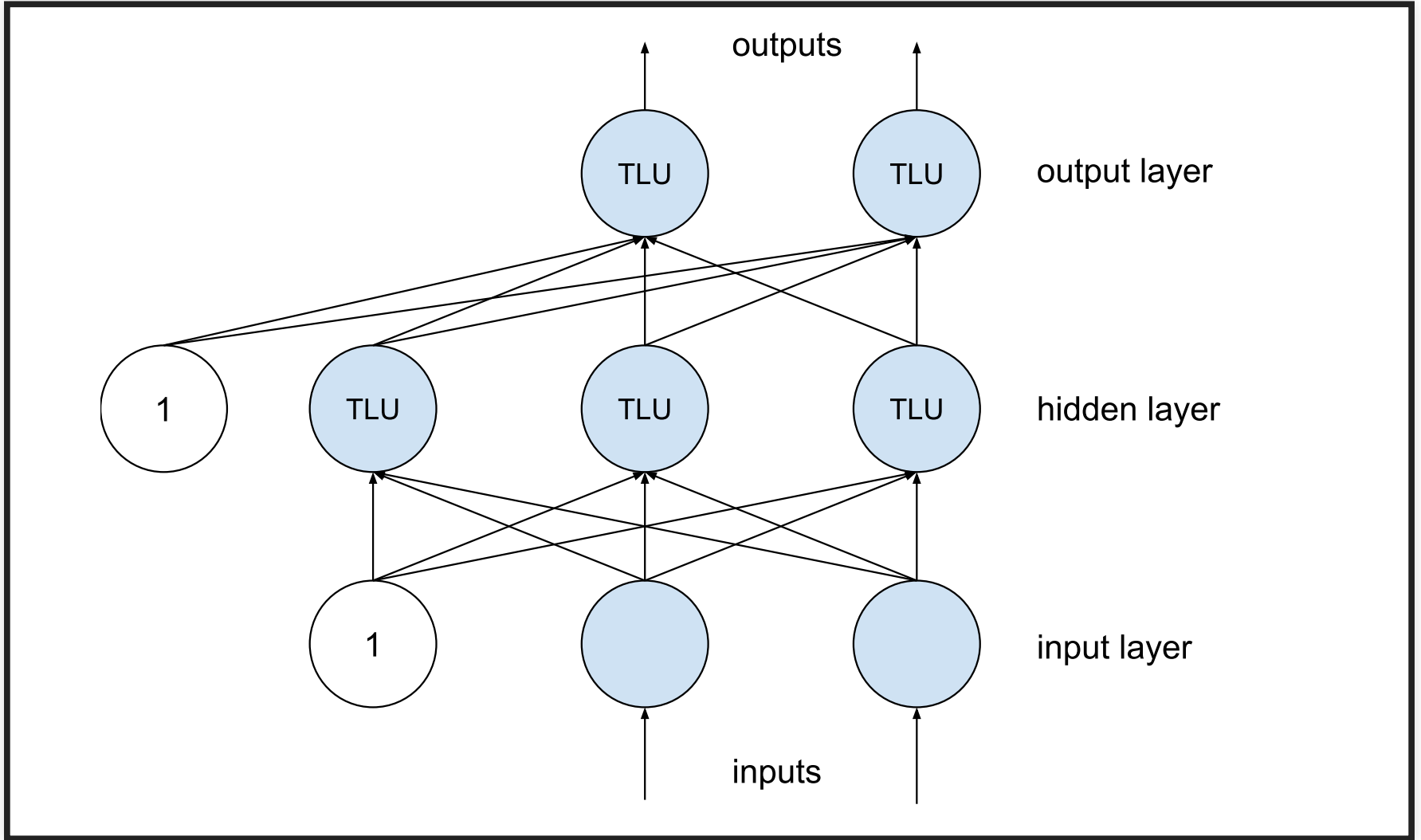

Speaker notes

Layers are fully connected here, but layers may have different numbers of neurons

$$f_{\mathbf{W}_h, \mathbf{b}_h, \mathbf{W}_o, \mathbf{b}_o}(\mathbf{X}) = \phi(\mathbf{W}_o \cdot \phi(\mathbf{W}_h \cdot \mathbf{X} + \mathbf{b}_h) + \mathbf{b}_o)$$

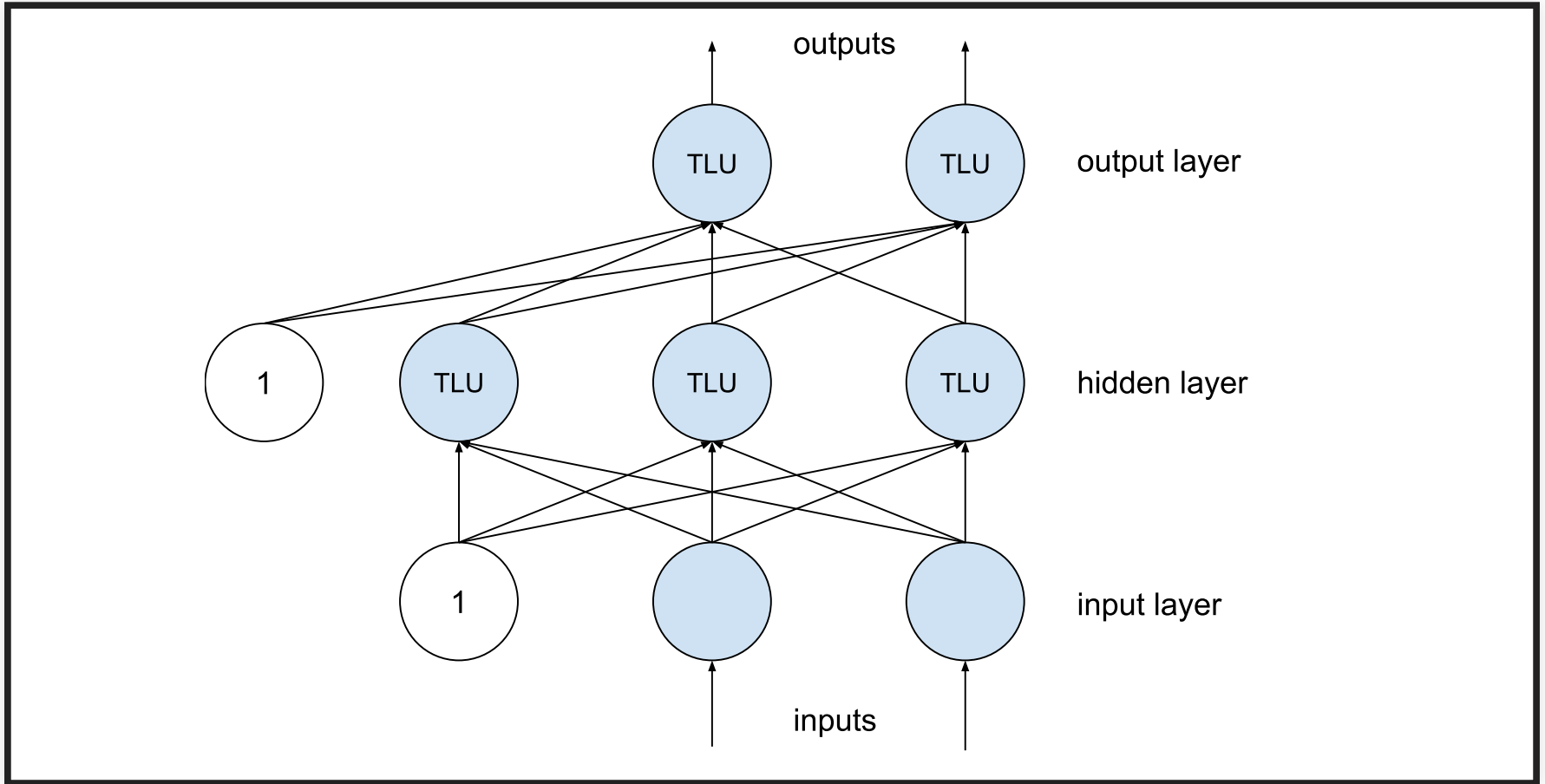

(matrix multiplications interleaved with step function)

LEARNING MODEL PARAMETERS (BACKPROPAGATION)

Intuition:

- Initialize all weights with random values
- Compute prediction, remembering all intermediate activations
- If output is not expected output (measuring error with a loss function),
 - compute how much each connection contributed to the error on output layer
 - repeat computation on each lower layer
 - tweak weights a little toward the correct output (gradient descent)
- Continue training until weights stabilize

Works efficiently only for certain ϕ , typically logistic function:

$$\phi(z) = 1/(1 + \exp(-z)) \text{ or ReLU: } \phi(z) = \max(0, z).$$

DEEP LEARNING

- More layers
- Layers with different numbers of neurons
- Different kinds of connections
 - fully connected (feed forward)
 - not fully connected (eg. convolutional networks)
 - keeping state (eg. recurrent neural networks)
 - skipping layers
 - ...

See Chapter 10 in [François](#) Géron, Aurélien. "[Hands-On Machine Learning with Scikit-Learn, Keras, and TensorFlow](#)", 2nd Edition (2019) or any other book on deep learning

Speaker notes

Essentially the same with more layers and different kinds of architectures.

EXAMPLE SCENARIO

- MNIST Fashion dataset of 70k 28x28 grayscale pixel images, 10 output classes

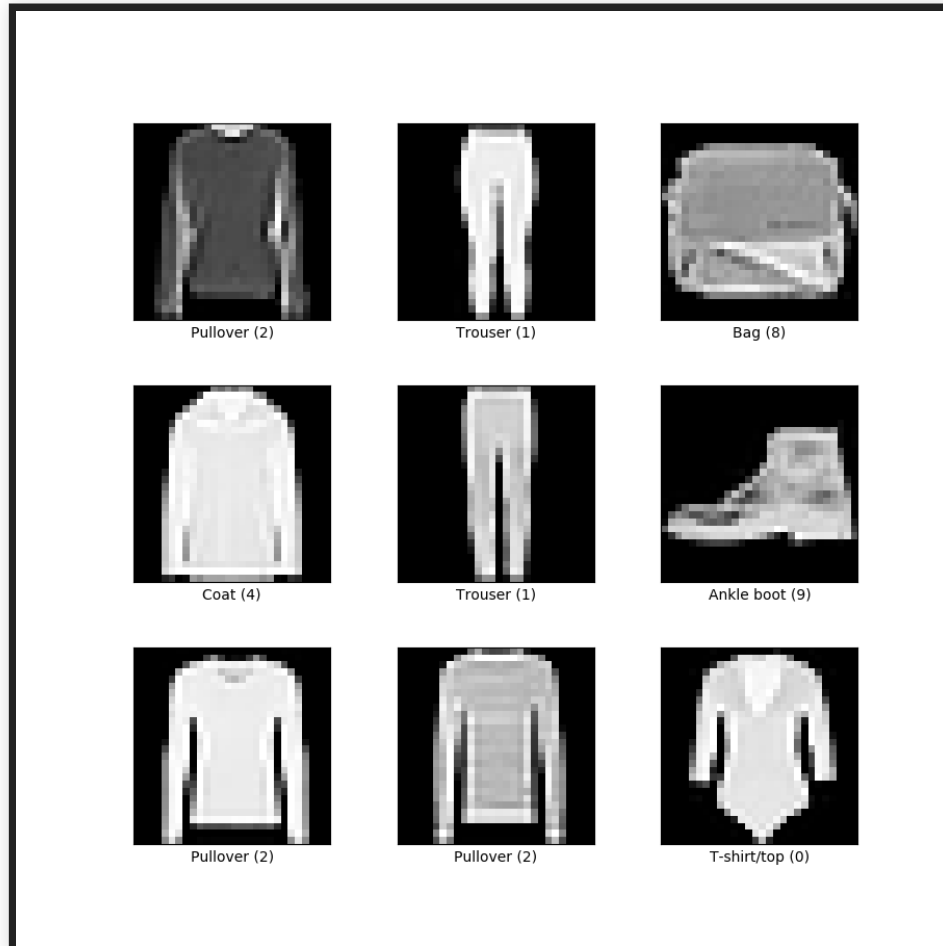

EXAMPLE SCENARIO

- MNIST Fashion dataset of 70k 28x28 grayscale pixel images, 10 output classes
- 28x28 = 784 inputs in input layers (each 0..255)
- Example model with 3 layers, 300, 100, and 10 neurons

```
model = keras.models.Sequential([
    keras.layers.Flatten(input_shape=[28, 28]),
    keras.layers.Dense(300, activation="relu"),
    keras.layers.Dense(100, activation="relu"),
    keras.layers.Dense(10, activation="softmax")
])
```

How many parameters does this model have?

EXAMPLE SCENARIO

- MNIST Fashion dataset of 70k 28x28 grayscale pixel images, 10 output classes
- 28x28 = 784 inputs in input layers (each 0..255)
- Example model with 3 layers, 300, 100, and 10 neurons

```
model = keras.models.Sequential([
    keras.layers.Flatten(input_shape=[28, 28]),
    # 784*300+300 = 235500 parameter
    keras.layers.Dense(300, activation="relu"),
    # 300*100+100 = 30100 parameters
    keras.layers.Dense(100, activation="relu"),
    # 100*10+10 = 1010 parameters
    keras.layers.Dense(10, activation="softmax")
])
```

Total of 266,610 parameters in this small example! (Assuming float types, that's 1 MB)

NETWORK SIZE

- 50 Layer ResNet network -- classifying 224x224 images into 1000 categories
 - 26 million weights, computes 16 million activations during inference, 168 MB to store weights as floats
- Google in 2012(!): 1TB-1PB of training data, 1 billion to 1 trillion parameters
- OpenAI's GPT-2 (2019) -- text generation
 - 48 layers, 1.5 billion weights (~12 GB to store weights)
 - released model reduced to 117 million weights
 - trained on 7-8 GPUs for 1 month with 40GB of internet text from 8 million web pages
- OpenAI's GPT-3 (2020): 96 layers, 175 billion weights, 700 GB in memory, \$4.6M in approximate compute cost for training

Speaker notes

<https://lambdalabs.com/blog/demystifying-gpt-3/>

COST & ENERGY CONSUMPTION

Consumption	CO2 (lbs)
Air travel, 1 passenger, NY ↔ SF	1984
Human life, avg, 1 year	11,023
American life, avg, 1 year	36,156
Car, avg incl. fuel, 1 lifetime	126,000
Training one model (GPU)	CO2 (lbs)
NLP pipeline (parsing, SRL)	39
w/ tuning & experimentation	78,468
Transformer (big)	192
w/ neural architecture search	626,155

Strubell, Emma, Ananya Ganesh, and Andrew McCallum. "[Energy and Policy Considerations for Deep Learning in NLP.](#)" In Proceedings of the 57th Annual Meeting of the Association for Computational Linguistics, pp. 3645-3650. 2019.

COST & ENERGY CONSUMPTION

Model	Hardware	Hours	CO2	Cloud cost in USD
Transformer	P100x8	84	192	289–981
ELMo	P100x3	336	262	433–1472
BERT	V100x64	79	1438	3751–13K
NAS	P100x8	274,120	626,155	943K–3.2M
GPT-2	TPUv3x32	168	—	13K–43K
GPT-3			—	4.6M

Strubell, Emma, Ananya Ganesh, and Andrew McCallum. "[Energy and Policy Considerations for Deep Learning in NLP](#)." In Proceedings of the 57th Annual Meeting of the Association for Computational Linguistics, pp. 3645-3650. 2019.

REUSING AND RETRAINING NETWORKS

- Incremental learning process enables continued training, retraining, incremental updates
- A model that captures key abstractions may be good starting point for adjustments (i.e., rather than starting with randomly initialized parameters)
- Reused models may inherit bias from original model
- Lineage important. Model cards promoted for documenting rationale, e.g., [Google Perspective Toxicity Model](#)

SOME COMMON QUALITIES

LEARNING COST? INCREMENTAL LEARNING?

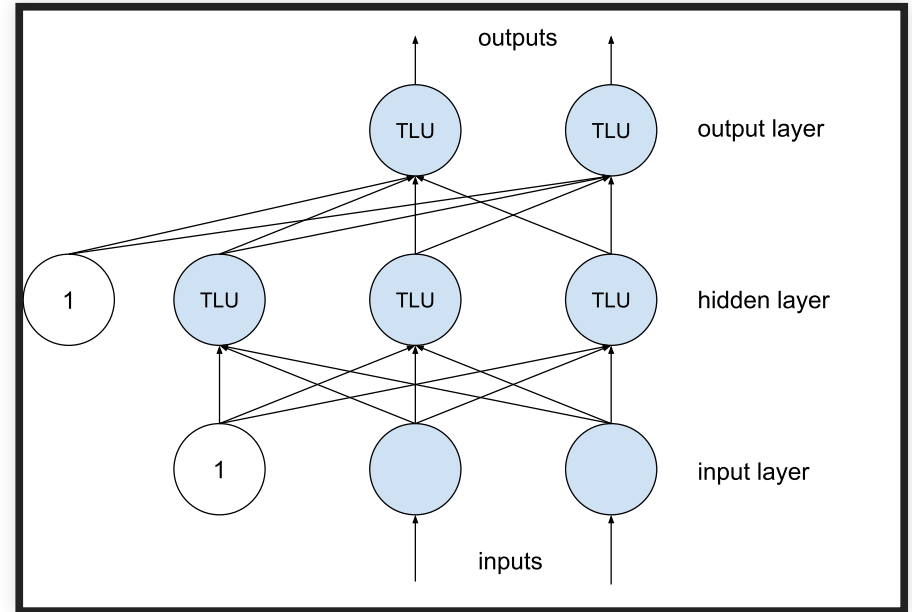
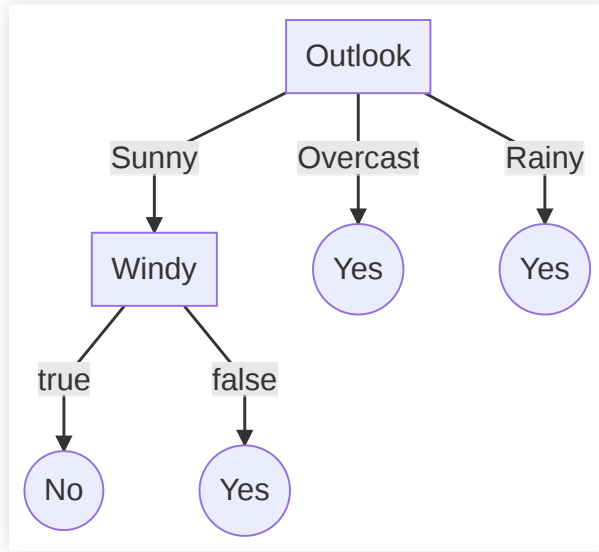

INFERENCE LATENCY AND COST?

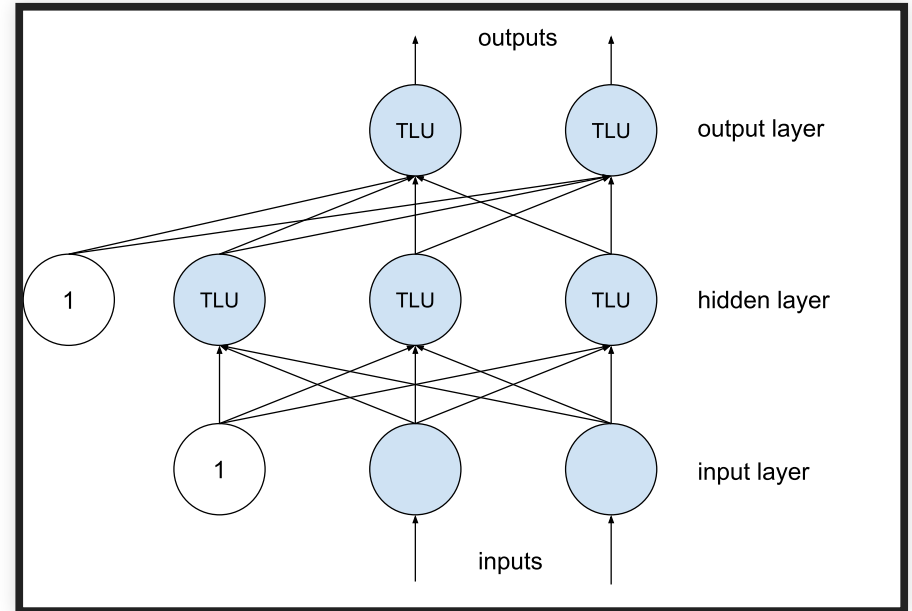
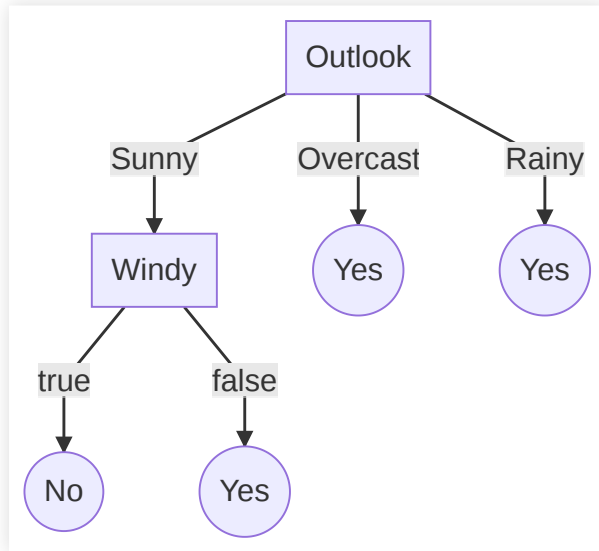

Inference time? Energy costs? Hardware needs? Mobile deployments? Realtime inference? Throughput and scalability?

INTERPRETABILITY/EXPLAINABILITY

"Why did the model predict X?"

Explaining predictions + Validating Models + Debugging

```
IF age between 18-20 and sex is male THEN predict arrest  
ELSE IF age between 21-23 and 2-3 prior offenses THEN predict ar  
ELSE IF more than three priors THEN predict arrest  
ELSE predict no arrest
```

Some models inherently simpler to understand

Some tools may provide post-hoc explanations

Explanations may be more or less truthful

How to measure interpretability?

more in a later lecture

ROBUSTNESS

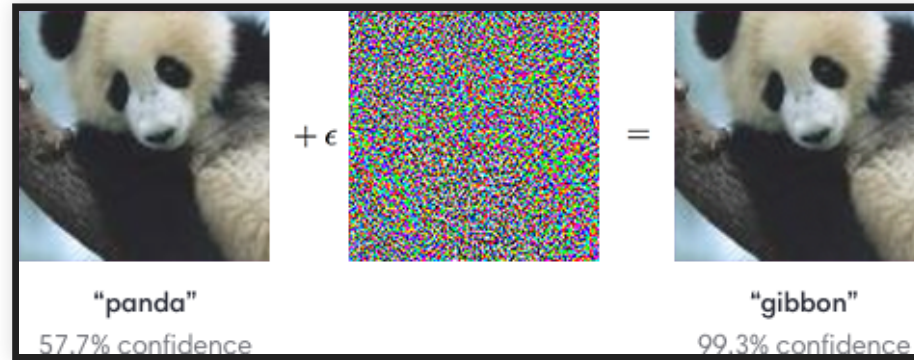

Small input modifications may change output

Small training data modifications may change predictions

How to measure robustness?

more in a later lecture

Image source: [OpenAI blog](#)

ROBUSTNESS OF DECISION TREES?

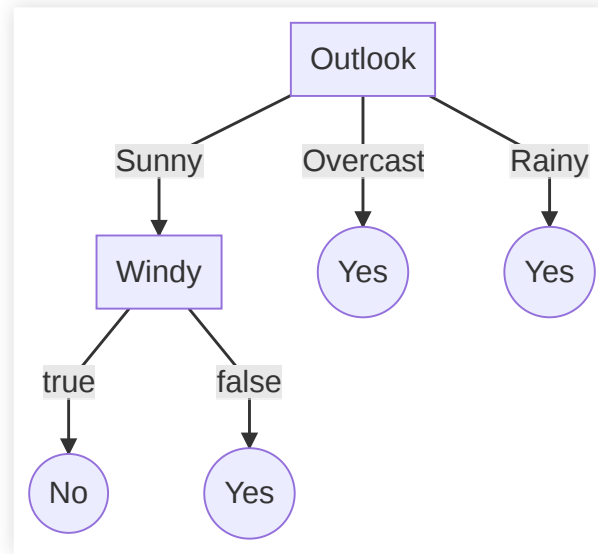

FAIRNESS

Does the model perform differently for different populations?

```
IF age between 18-20 and sex is male THEN predict arrest  
ELSE IF age between 21-23 and 2-3 prior offenses THEN predict ar  
ELSE IF more than three priors THEN predict arrest  
ELSE predict no arrest
```

Many different notions of fairness

Often caused by bias in training data

Enforce invariants in model or apply corrections outside model

Important consideration during requirements solicitation!

more in a later lecture

REQUIREMENTS ENGINEERING FOR AI-ENABLED SYSTEMS

- Set minimum accuracy expectations ("functional requirement")
- Identify runtime needs (how many predictions, latency requirements, cost budget, mobile vs cloud deployment)
- Identify evolution needs (update and retrain frequency, ...)
- Identify explainability needs
- Identify protected characteristics and possible fairness concerns
- Identify security and privacy requirements (ethical and legal), e.g., possible use of data
- Understand data availability and need (quality, quantity, diversity, formats, provenance)
- Involve data scientists and legal experts
- **Map system goals to AI components**

Further reading: Vogelsang, Andreas, and Markus Borg. "[Requirements Engineering for Machine Learning: Perspectives from Data Scientists](#)." In Proc. of the 6th International Workshop on Artificial Intelligence for Requirements Engineering (AIRE), 2019.

REQUIREMENTS ENGINEERING PROCESS

- Interview stakeholders (customers, operators, developers, business experts)
 - Understand the problem, the kind of prediction needed (e.g. classification)
 - Understand the scope: target domain, frequency of change, ...
- Broadly understand quality needs from different views
 - Model view: direct expectation on the model(s)
 - Data view: availability, quantity, and quality of data
 - System view: understand system goals and role of ML model and interactions with environment
 - Infrastructure view: training cost, reproducibility needs, serving infrastructure needs, monitoring needs, ...
 - Environment/user view: external expectations on the system by users and society, e.g. fairness, safety
- Collect and document needs, resolve conflicts, discuss and prioritize

Siebert, Julien, Lisa Joeckel, Jens Heidrich, Koji Nakamichi, Kyoko Ohashi, Isao Namba, Rieko Yamamoto, and Mikio Aoyama. "[Towards Guidelines for Assessing Qualities of Machine Learning Systems](#)." In International Conference on the Quality of Information and Communications Technology, pp. 17-31. Springer, Cham, 2020.

RECALL: QUALITIES OF INTEREST?

Consider model view, data view, system view, infrastructure view, environment view

the-changelog-318 Last saved a few seconds ago ... Share

[← Dashboard](#) | **Quality:** High ⓘ

00:00 Offset 00:00 01:31:27

▶ Play ↶ Back 5s 1x Speed 🔊 Volume

NOTES
Write your notes here

Speaker 5 ▶ 07:44

Yeah. So there's a slight story behind that. So back when I was in, **uh**, Undergrad, I wrote a program for myself to measure a, **the** amount of time I did data entry **from** my father's business and I was on windows at the time and there wasn't a function called time dot **[inaudible]** time, **uh**, which I **needed** to parse dates to get back to time, **top** of representation, **uh**, I figured out a way to do it and I gave it to what's called the python cookbook because it just seemed like something other people could use. So **it was** just trying to be helpful. **Uh**, subsequently I had to figure out how to make it work **because** I didn't really have to. Basically, it bothered me that you had to input all the **locale** information and I figured out how to do it over **the subsequent months**. And actually as a graduation gift from my Undergrad, the week following, I solved it and wrote it all out.

Speaker 5 ▶ 08:38

And I asked, **uh**, Alex Martelli, the editor of the Python Cookbook, which had published my original recipe, **a**, how do I get this into python? I think **it** might help

How did we do on your transcript? ☆☆☆☆☆

Speaker notes

Which of the previously discussed qualities are relevant? Which additional qualities may be relevant here? Cost per transaction?

RECALL: QUALITIES OF INTEREST?

Consider model view, data view, system view, infrastructure view, environment view

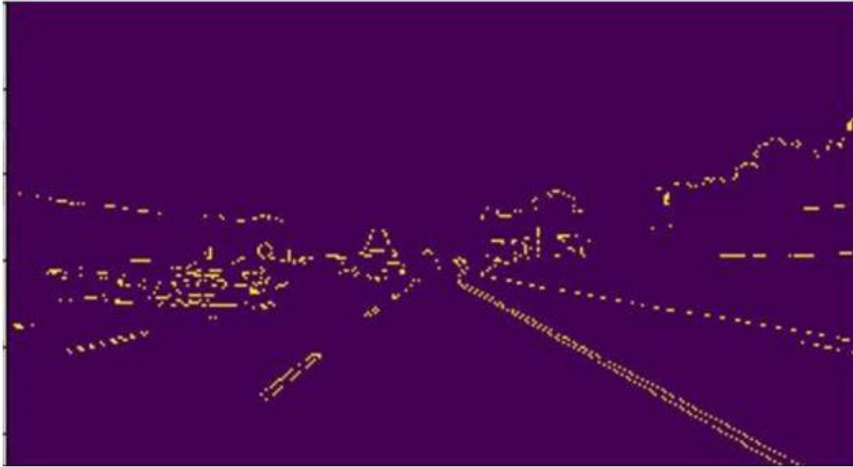

Canny edge detection output

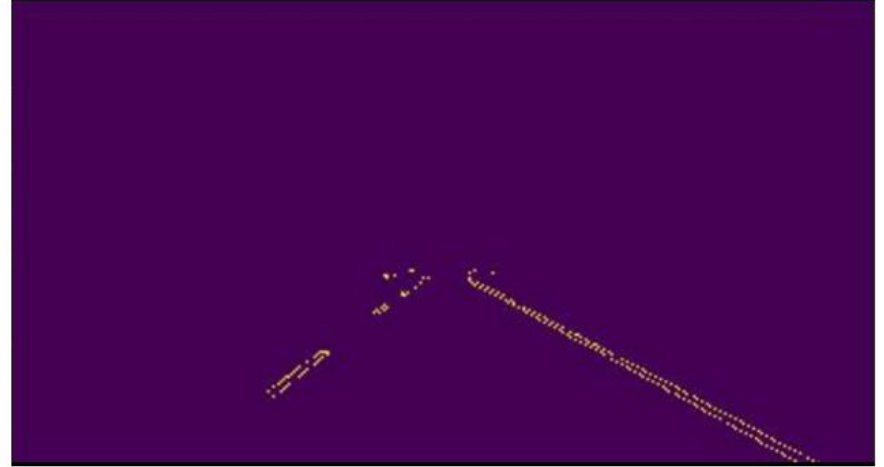

Hough transform output

Speaker notes

Which of the previously discussed qualities are relevant? Which additional qualities may be relevant here? Realtime use

RECALL: QUALITIES OF INTEREST?

Consider model view, data view, system view, infrastructure view, environment view



Note: Very high volume of transactions, low cost per transaction, frequent updates

CONSTRAINTS AND TRADEOFFS

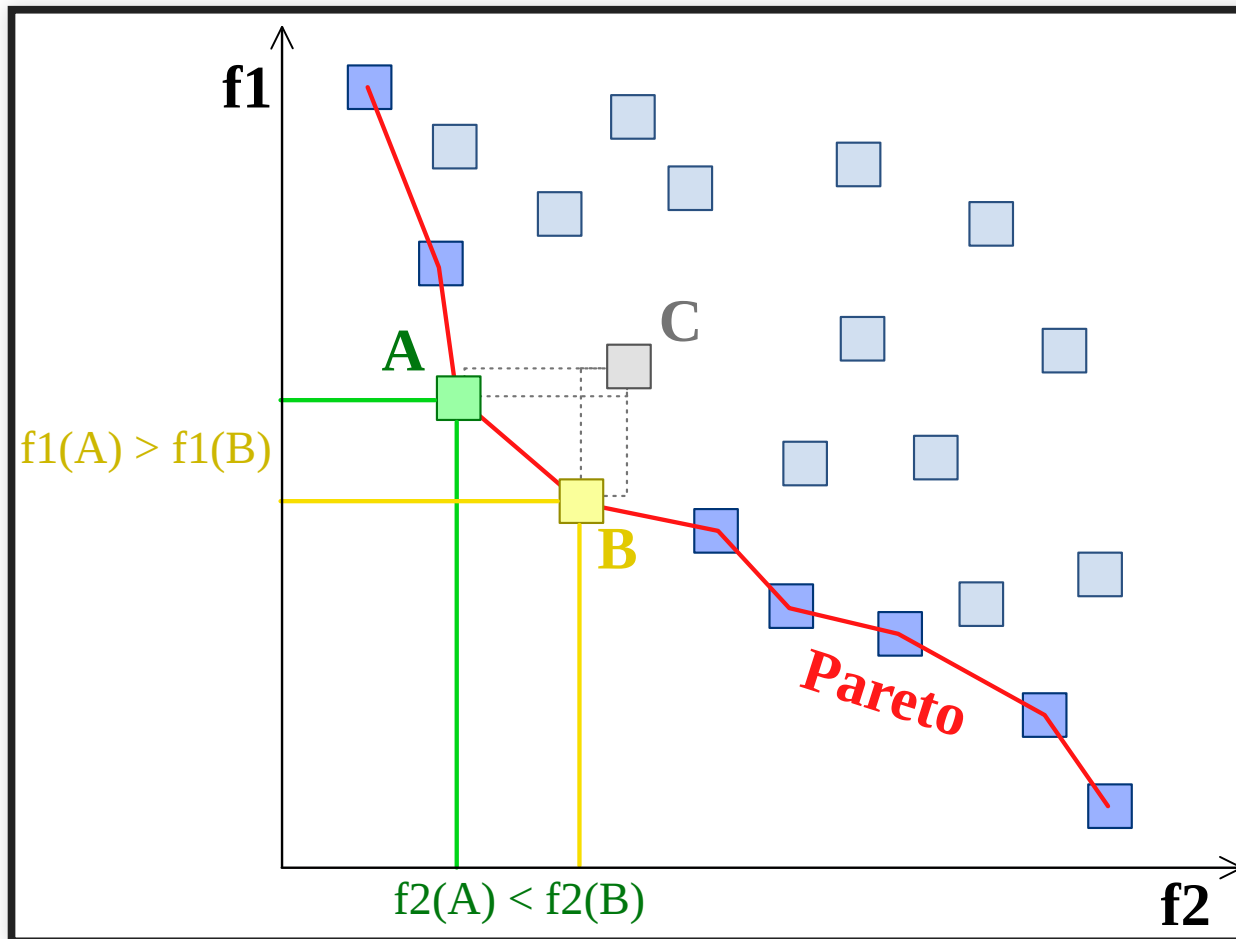

CONSTRAINTS

Constraints define the space of attributes for valid design solutions

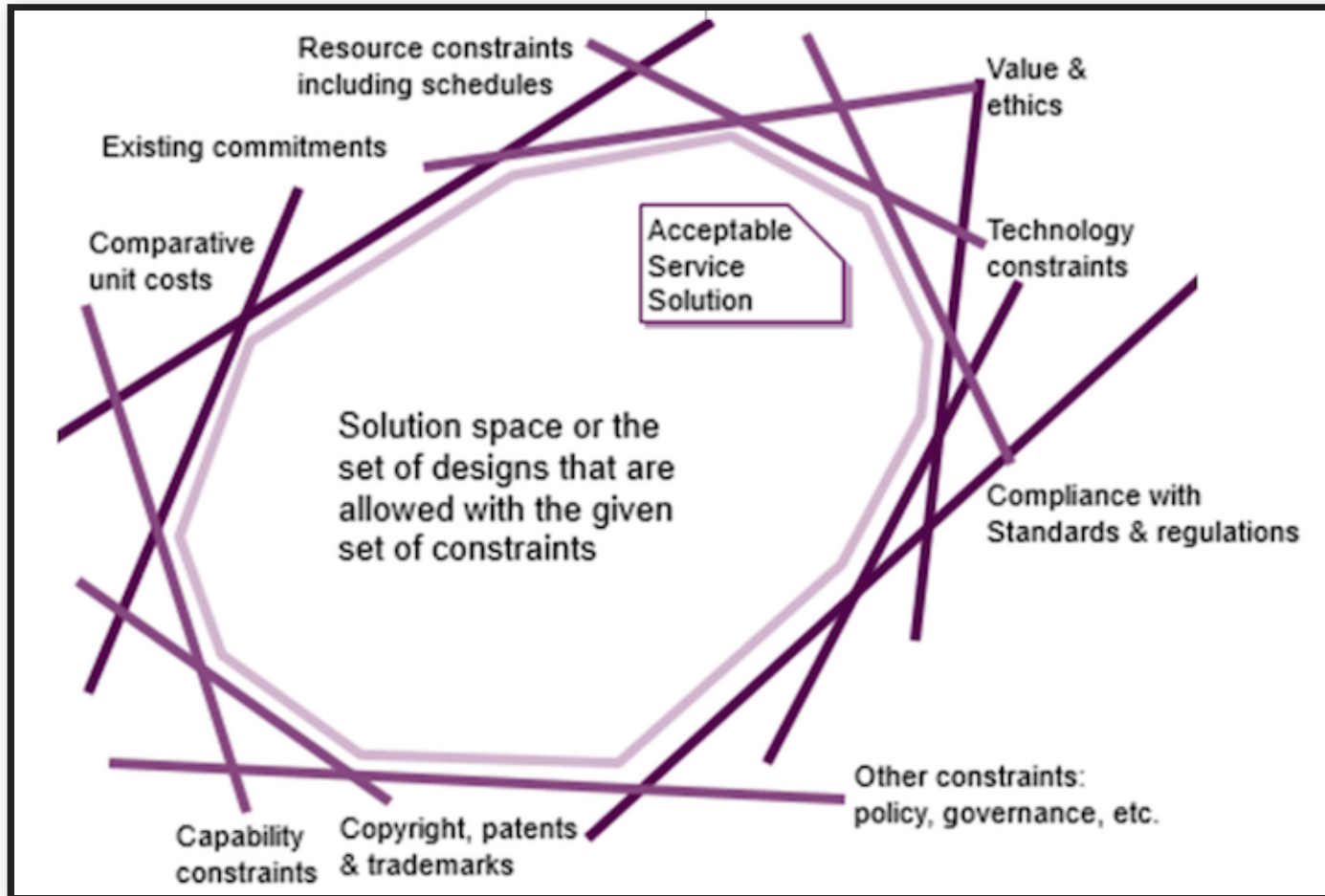

TYPES OF CONSTRAINTS

- Problem constraints: Minimum required QAs for an acceptable product
- Project constraints: Deadline, project budget, available skills
- Design constraints: Type of ML task required (regression/classification), kind of available data, limits on computing resources, max. inference cost

Plausible constraints for Fraud Detection?



AI SELECTION PROBLEM

- How to decide which AI method to use in project?
- Find method that:
 1. satisfies the given constraints and
 2. is optimal with respect to the set of relevant attributes

TRADE-OFFS: COST VS ACCURACY



NetfliX Prize

COMPLETED

Home Rules Leaderboard Update Download

Leaderboard

Showing Test Score. [Click here to show quiz score](#)

Display top leaders.

Rank	Team Name	Best Test Score	% Improvement	Best Submit Time
Grand Prize - RMSE = 0.8567 - Winning Team: BellKor's Pragmatic Chaos				
1	BellKor's Pragmatic Chaos	0.8567	10.06	2009-07-26 18:18:28
2	The Ensemble	0.8567	10.06	2009-07-26 18:38:22
3	Grand Prize Team	0.8582	9.90	2009-07-10 21:24:40
4	Opera Solutions and Vandelay United	0.8588	9.84	2009-07-10 01:12:31
5	Vandelay Industries!	0.8591	9.81	2009-07-10 00:32:20
6	PragmaticTheory	0.8594	9.77	2009-06-24 12:06:56
7	BellKor in BioChaos	0.8601	9.70	2009-05-13 08:14:09
8	Dace	0.8612	9.59	2009-07-24 17:18:43

"We evaluated some of the new methods offline but the additional accuracy gains that we measured did not seem to justify the engineering effort needed to bring them into a production environment."

TRADE-OFFS: ACCURACY VS INTERPRETABILITY

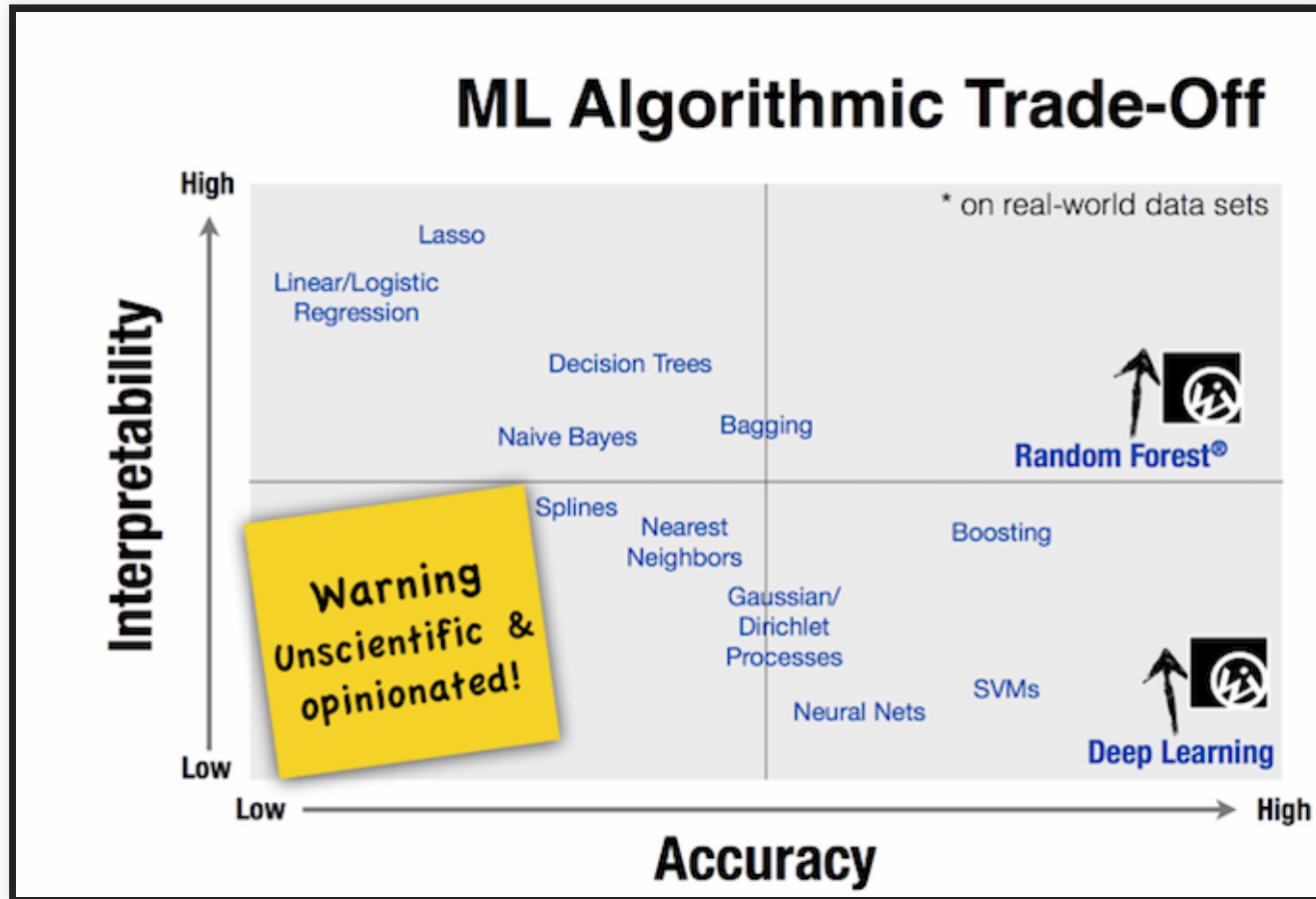

Bloom & Brink. [Overcoming the Barriers to Production-Ready Machine Learning Workflows](#), Presentation at O'Reilly Strata Conference (2014).

MULTI-OBJECTIVE OPTIMIZATION

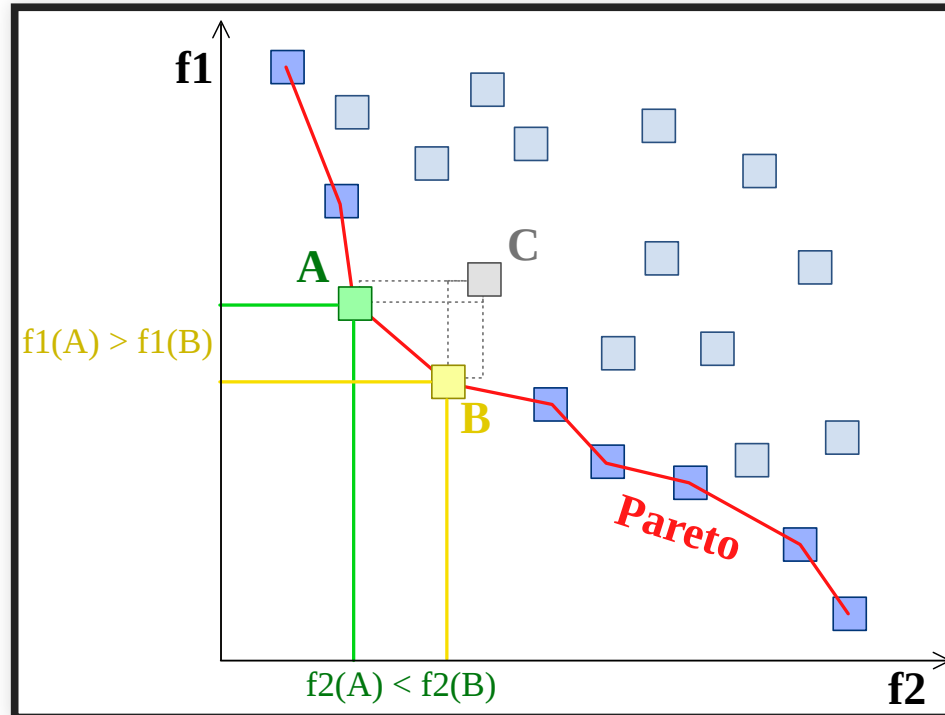

- Determine optimal solutions given multiple, possibly **conflicting** objectives
- **Dominated** solution: A solution that is inferior to others in every way
- **Pareto frontier**: A set of non-dominated solutions

Image CC BY-SA 3.0 by [Nojhan](#)

EXAMPLE: CREDIT SCORING

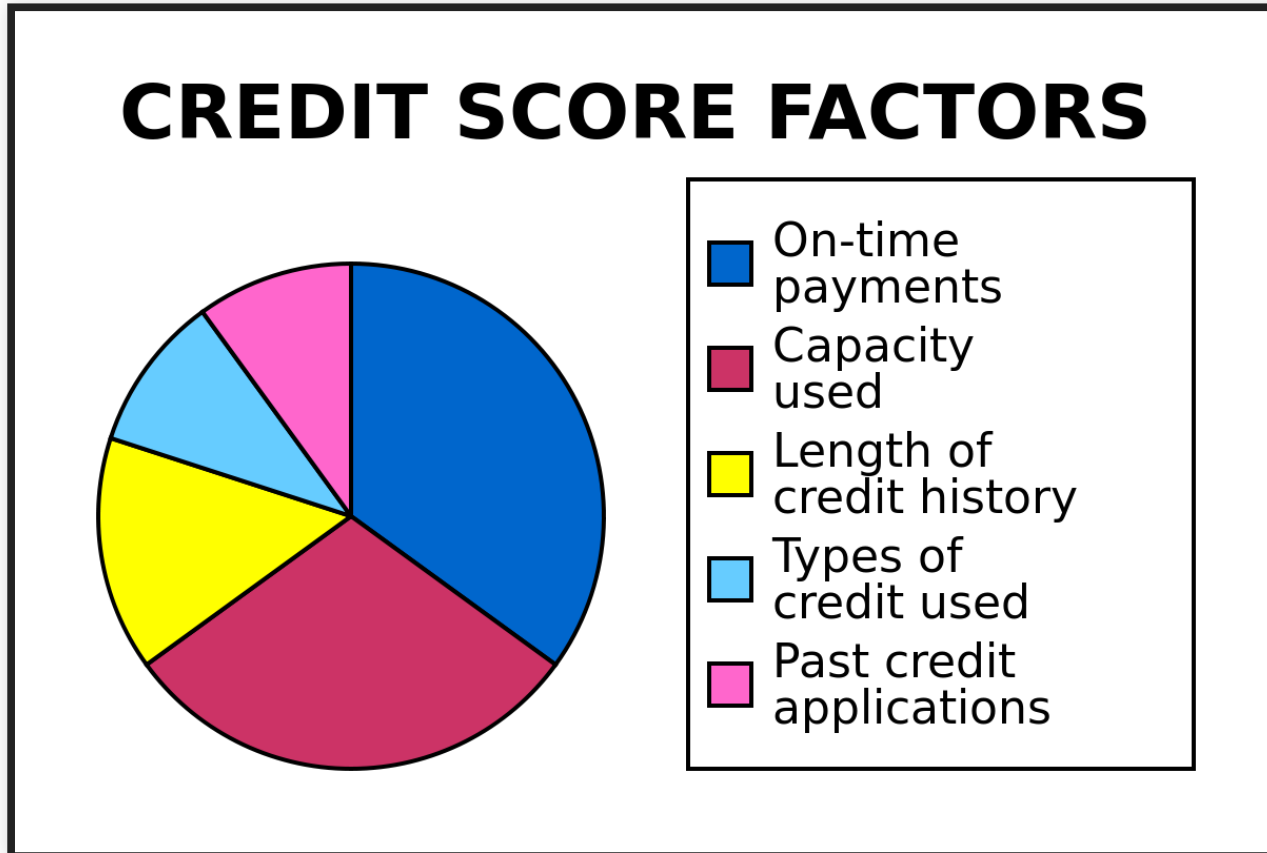

- For problems with a linear relationship between input & output variables:
 - Linear regression: Superior in terms of accuracy, interpretability, cost
 - Other methods are dominated (inferior) solutions

ML METHOD SELECTION AS MULTI-OBJECTIVE OPTIMIZATION

1. Identify a set of constraints
 - Start with problem & project constraints
 - From them, derive design constraints on ML components
2. Eliminate ML methods that do not satisfy the constraints
3. Evaluate remaining methods against each attribute
 - Measure everything that can be measured! (e.g., training cost, accuracy, inference time...)
4. Eliminate dominated methods to find the Pareto frontier
5. Consider priorities among attributes to select an optimal method
 - Which attribute(s) do I care the most about? Utility function?
Judgement!

EXAMPLE: CARDIOVASCULAR RISK PREDICTION



- Features: Age, gender, blood pressure, cholestorol level, max. heart rate, ...
- Constraints: Accuracy must be higher than baseline
- Invalid solutions: ??
- Priority among attributes: ??

SUMMARY

- Quality is multifaceted
- Requirements engineering to solicit important qualities and constraints
- Many qualities of interest, define metrics and operationalize
- Constraints and tradeoff analysis for selecting ML techniques in production ML settings

